

1 DAR PRO Solutions

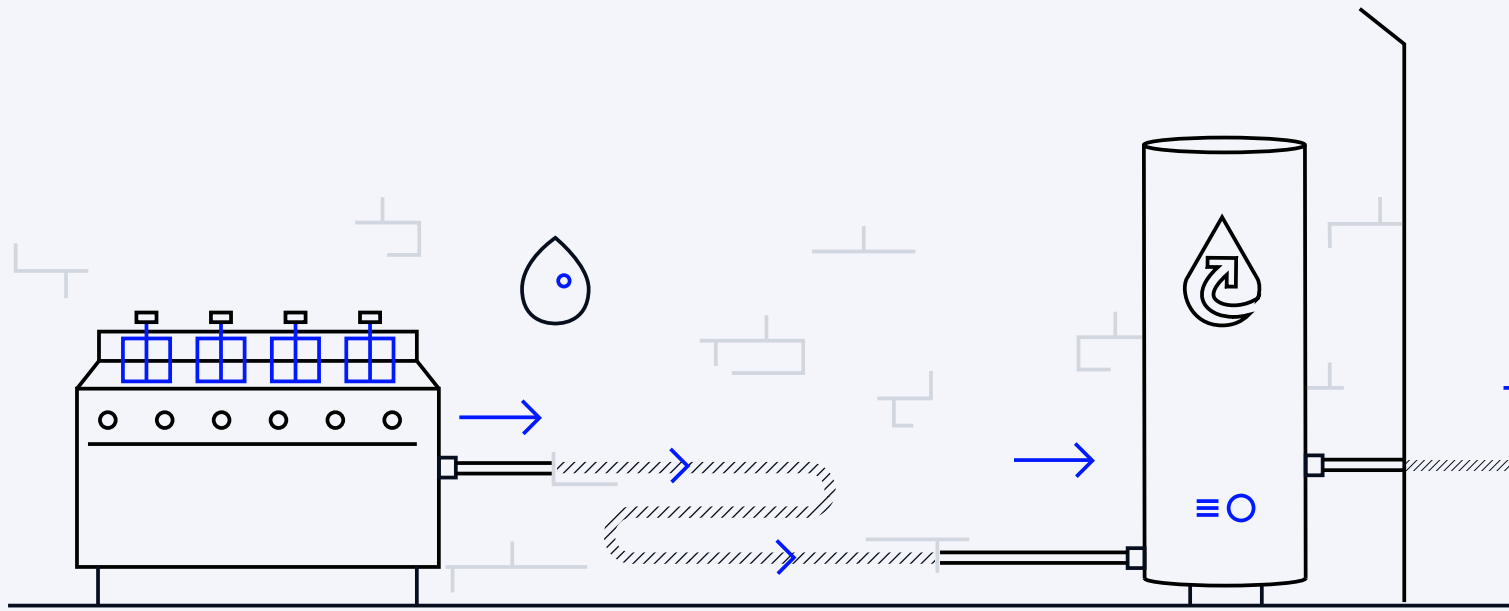

When used cooking oil (UCO) reaches end of life in a commercial or restaurant kitchen, safe disposal is vital to protect people and the environment — and maintain smooth kitchen operations.

DAR PRO Solutions' state-of-the-art equipment systems connect directly to fryers for quick, effortless UCO draining with the touch of a button. Experience the ultimate in convenience with seamless piped connections, discreetly installed behind walls or in ceilings.

We take it from here. Our trained experts collect UCO via a secure, external connection, enabling efficient, 24-hour-a-day, 7-day-a-week service that keeps our customers running without interruption.

2 Darling Ingredients U.S. Rendering

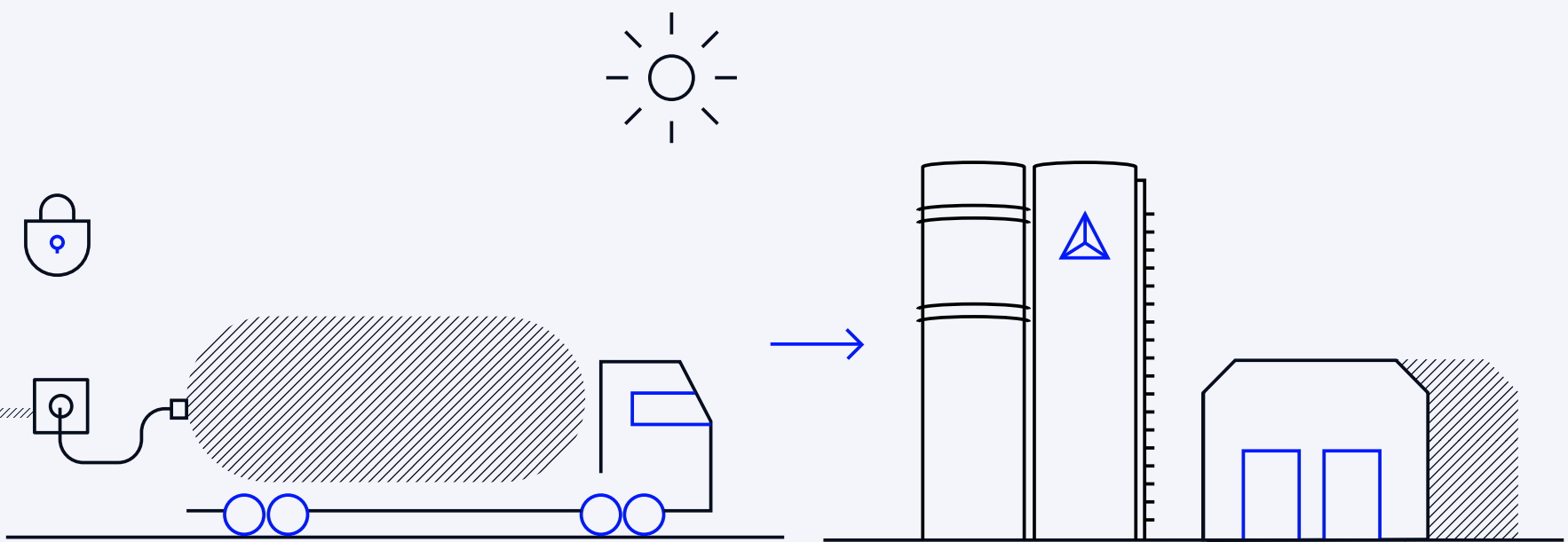

UCO is processed to be transformed into a low-carbon-intensity feedstock for renewable fuel

3 Renewables refinery

Rendered UCO sent by truck and rail tankers to be transformed into renewable diesel and sustainable aviation fuel, a reliable, sustainable alternative to traditional fossil fuels. We often send our UCO to Darling Ingredients' 50/50 joint venture Diamond Green Diesel — North America's largest producer of renewable fuel.

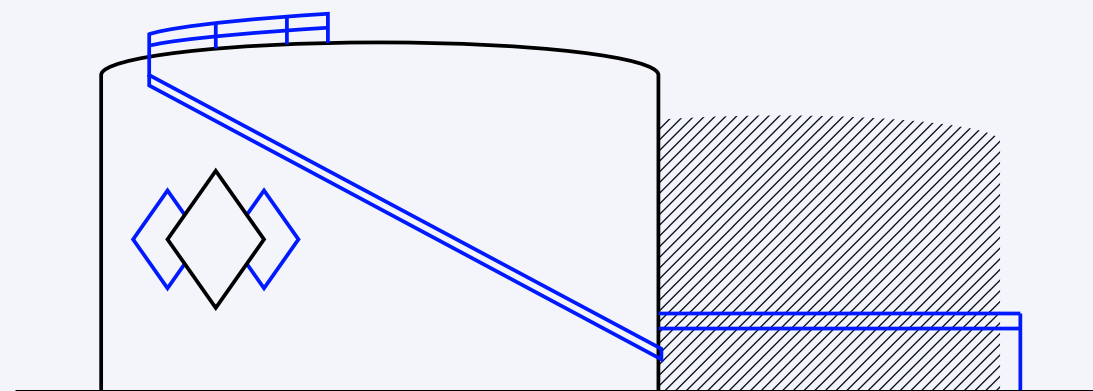

4 Making an impact

Our customers feel good knowing that what started in their kitchen is helping society decarbonize. Renewable diesel is 100% compatible with existing engines and infrastructure. It is a versatile, drop-in fuel that can be transported directly via pipeline, rail or ocean carrier and produces up to 80% fewer lifecycle greenhouse gas emissions than traditional fuel.

